

GOVERNOR

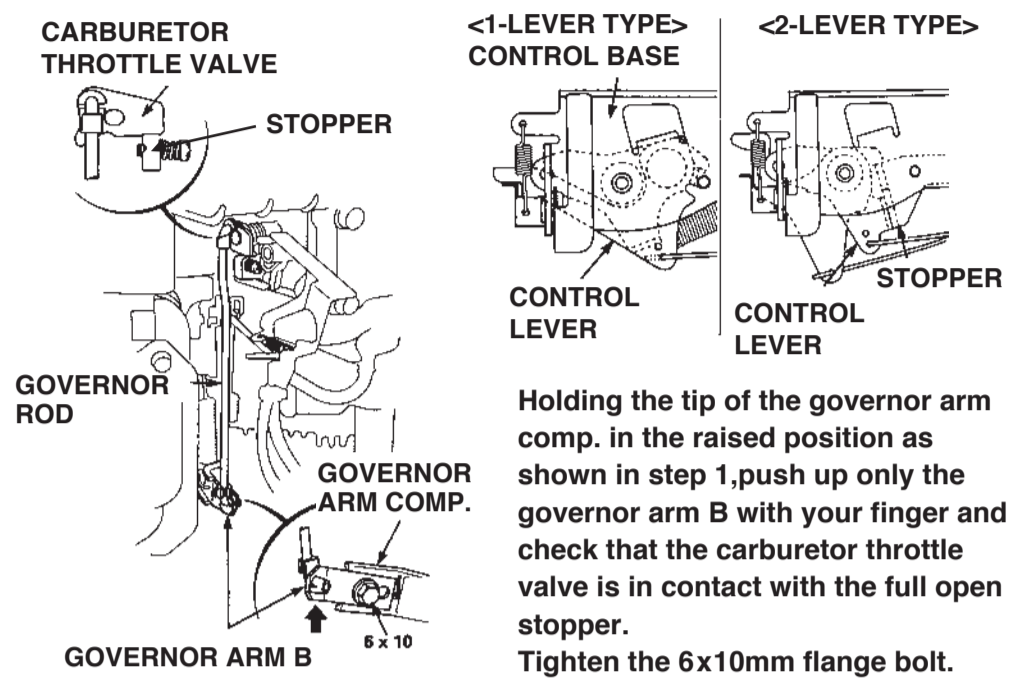

VALVE CLEARANCE

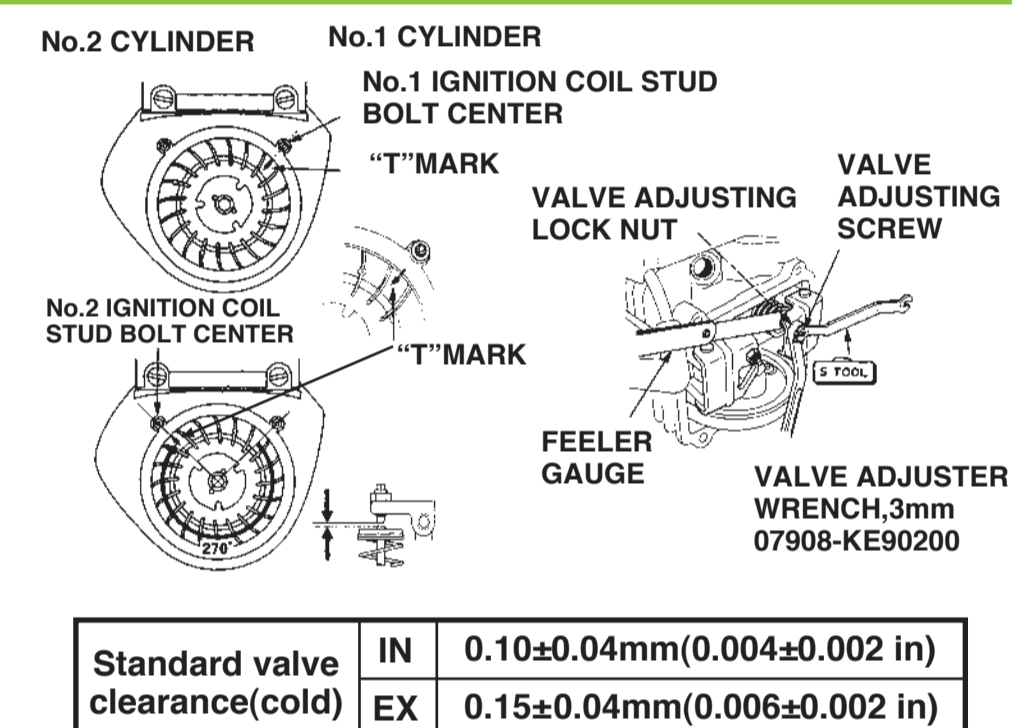

IGNITION COIL AIR GAP

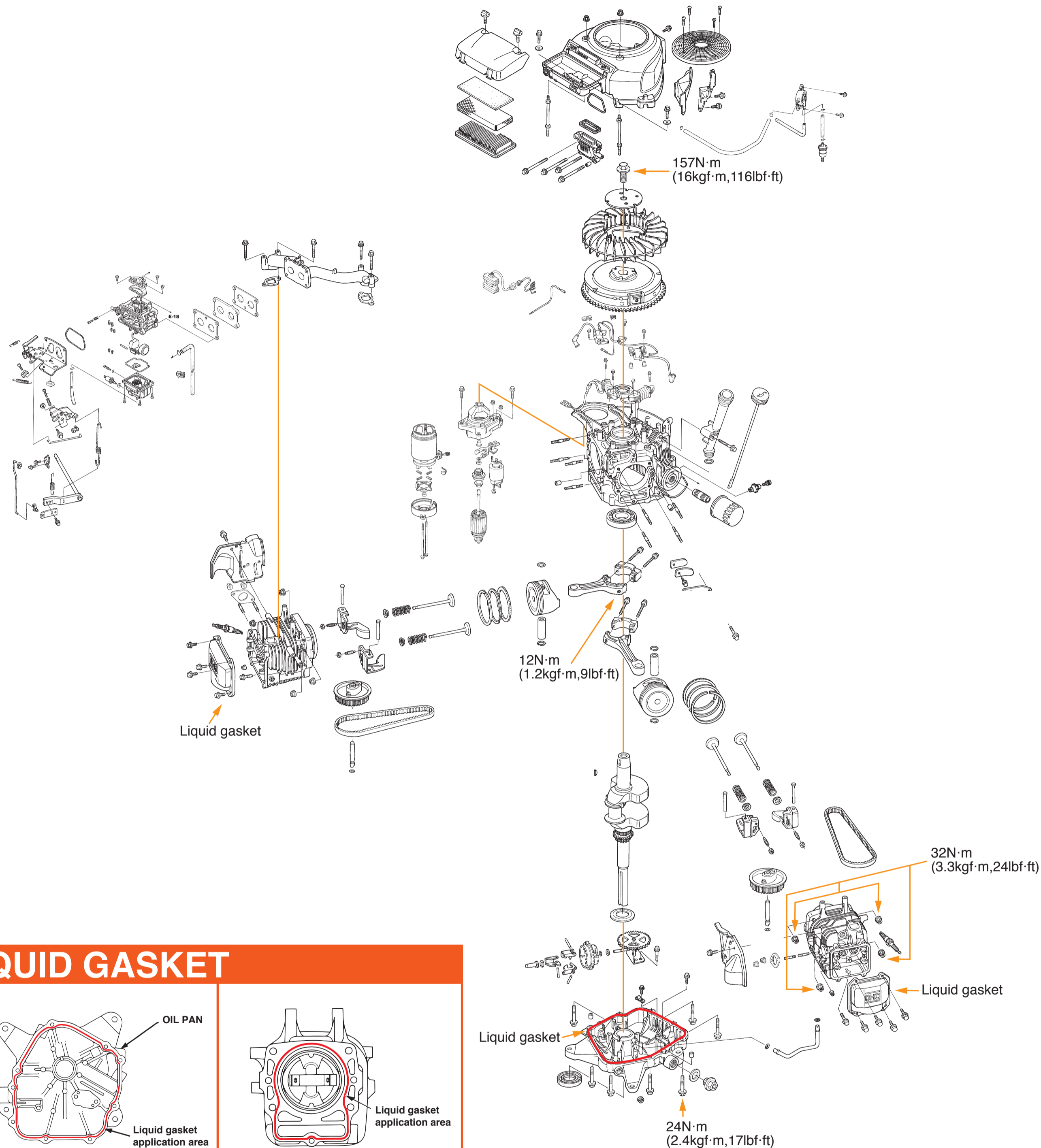
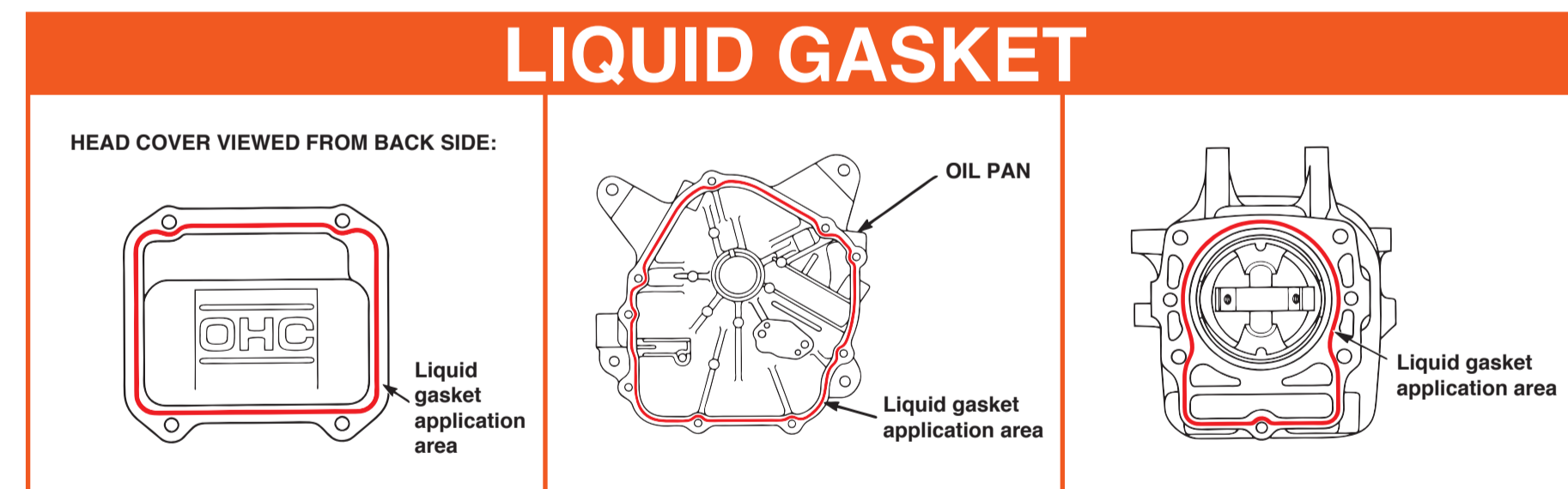
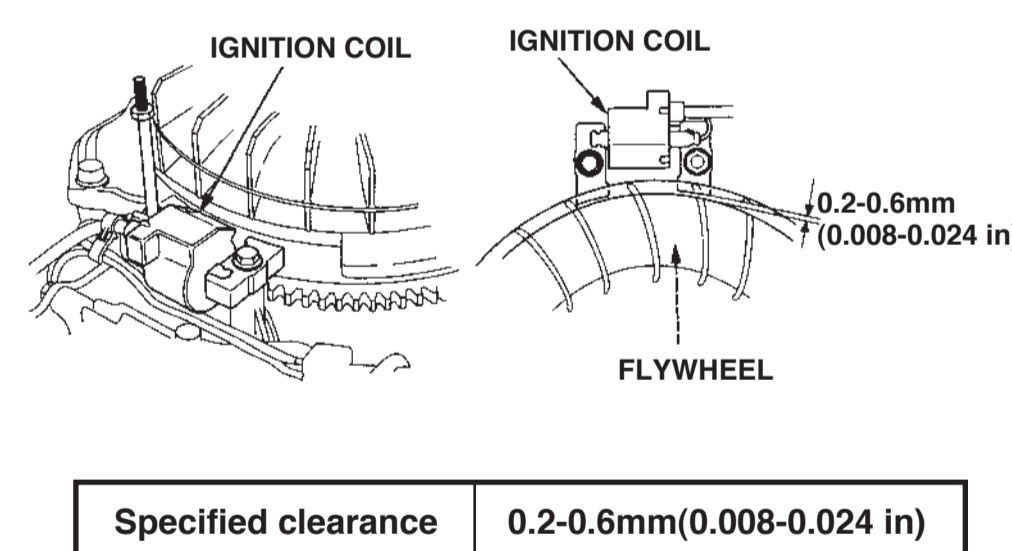

© Honda Motor Co., Ltd. Power Product Service Division.

ENGINE OIL

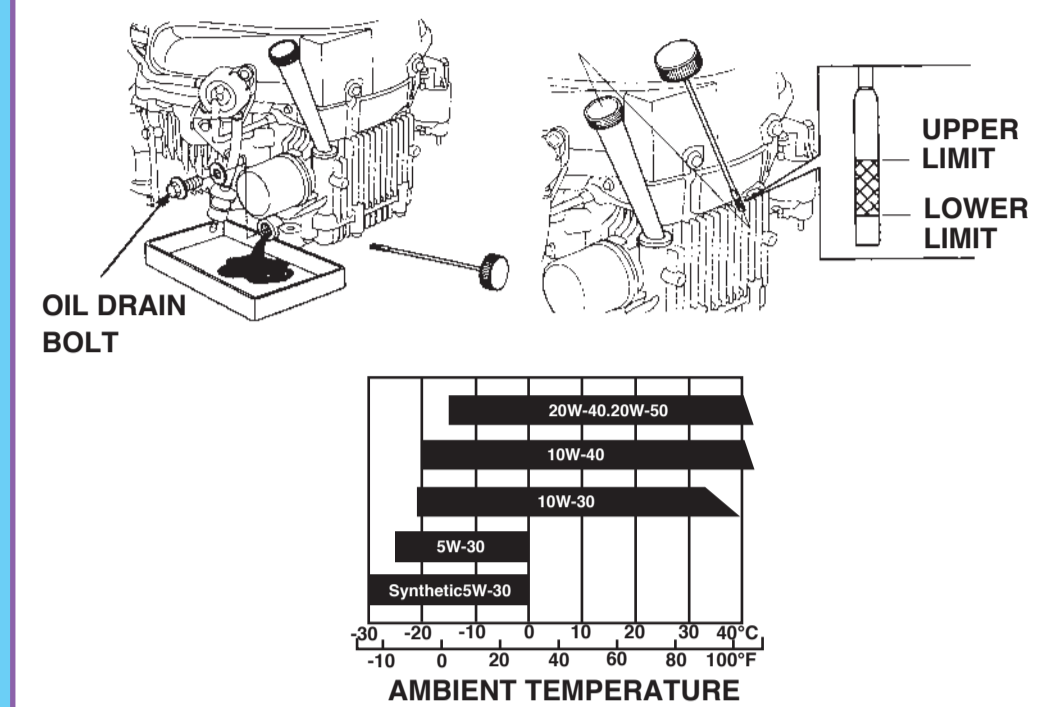

AIR CLEANER

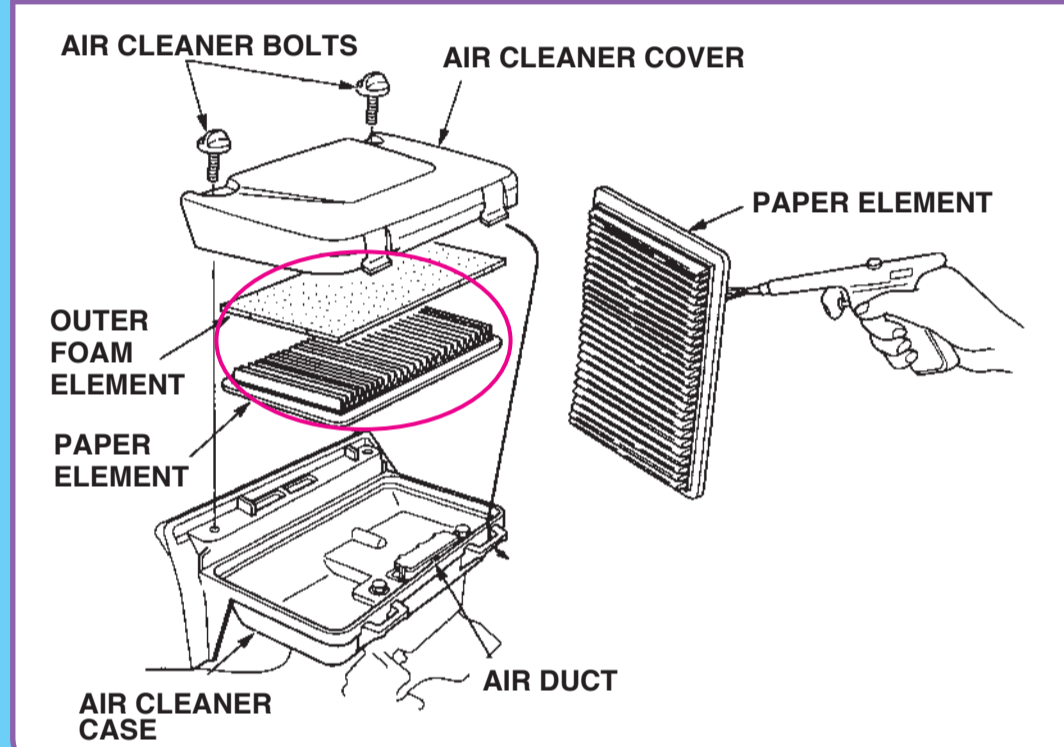

SPARK PLUG

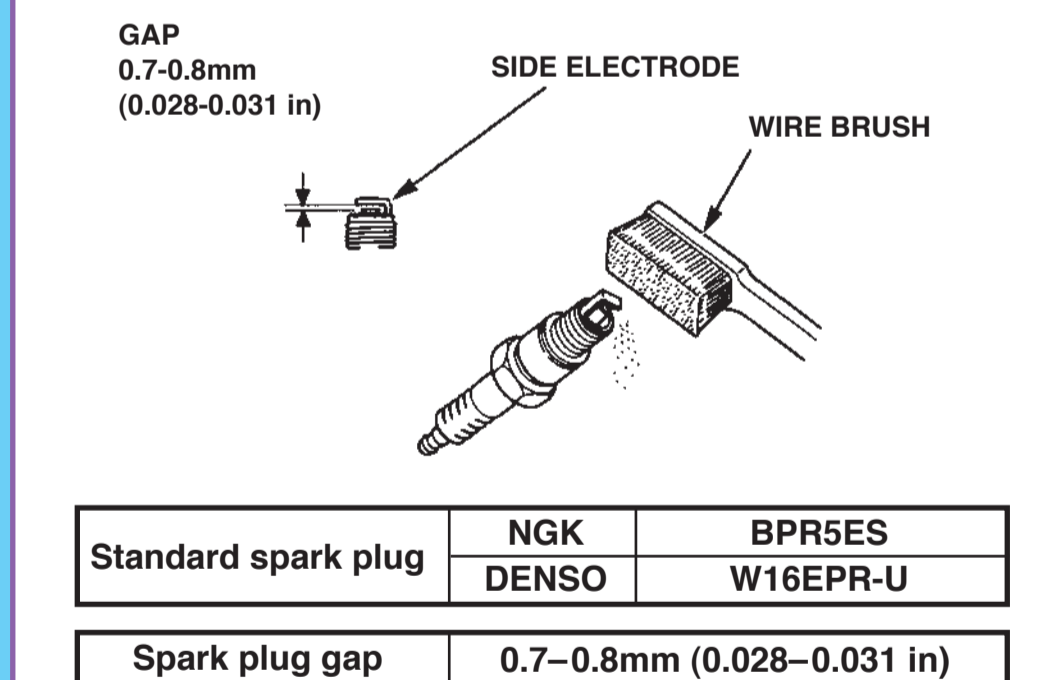

PISTON DISASSEMBLY/REASSEMBLY

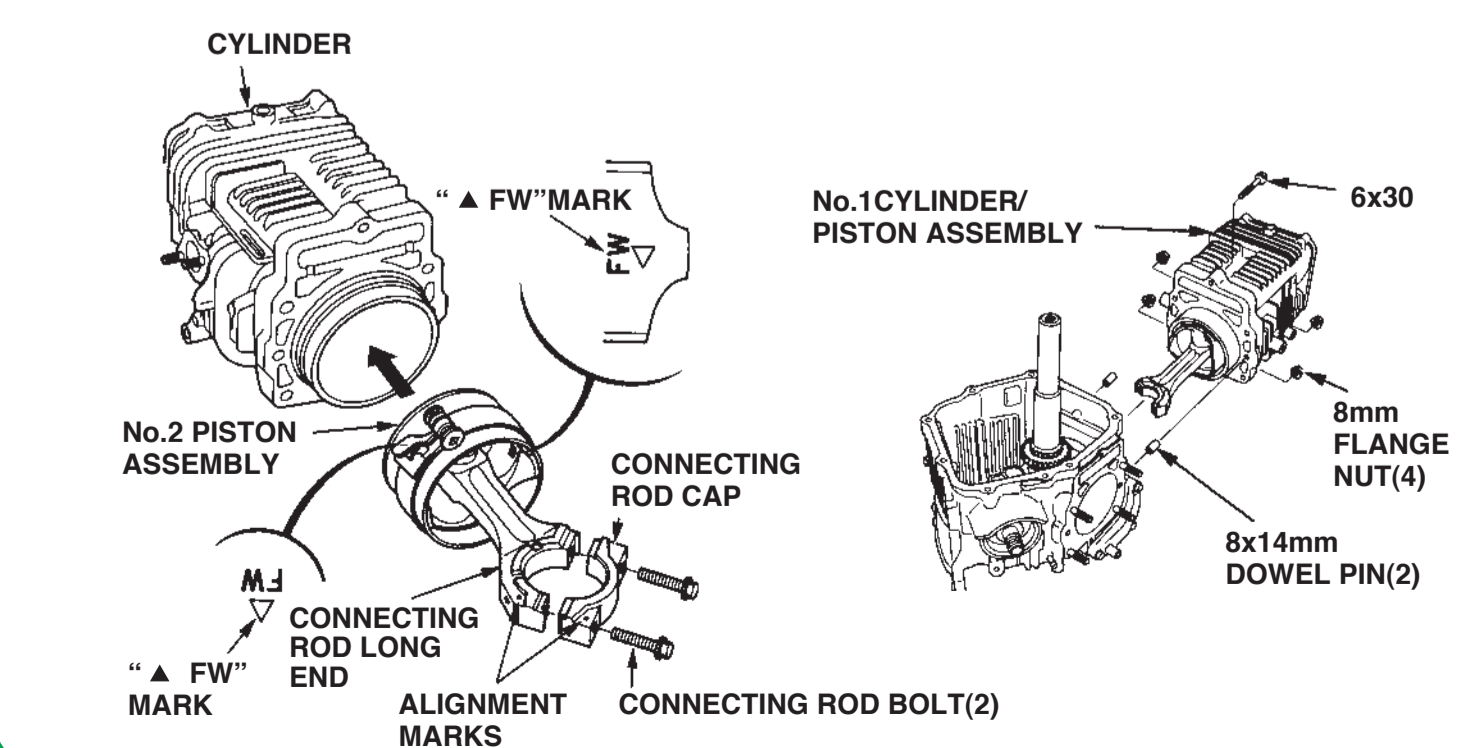

CAMSHAFT

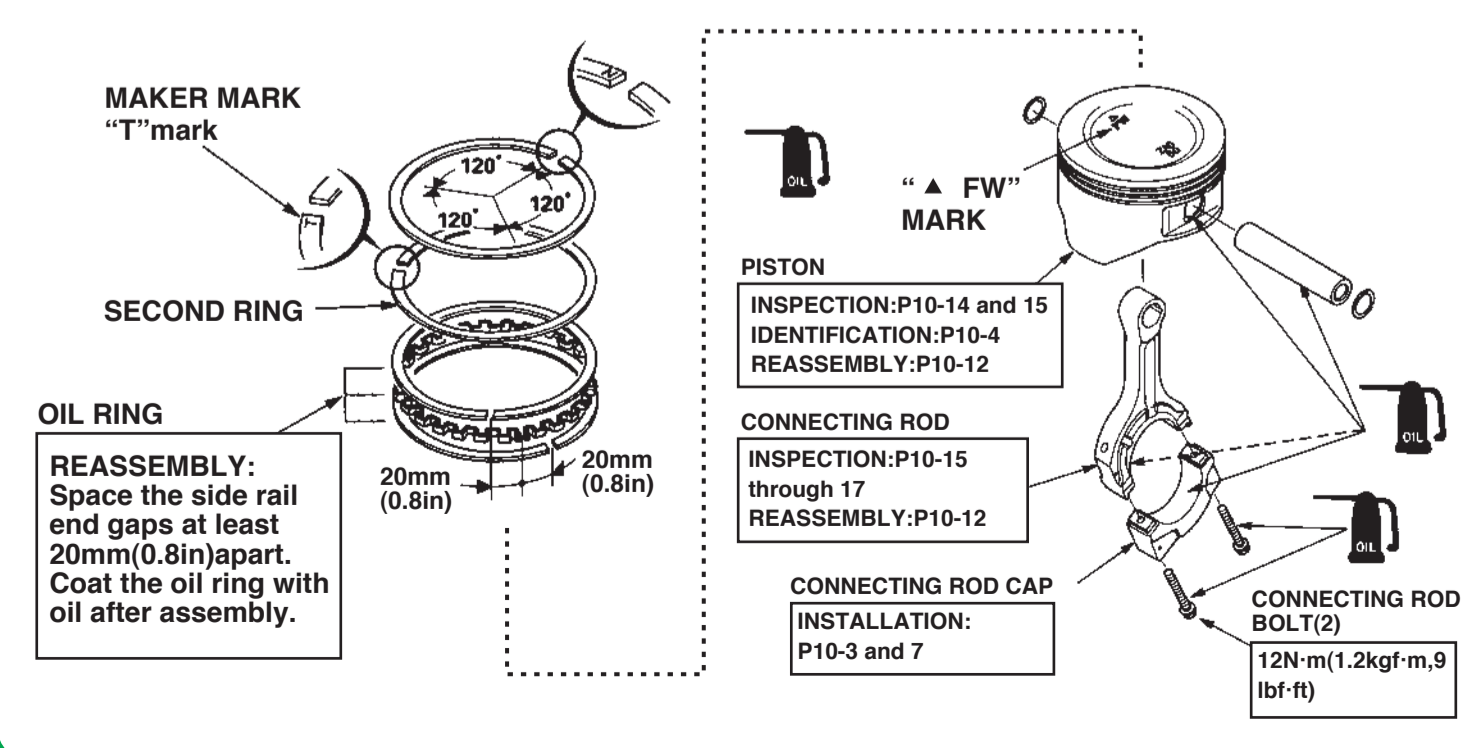

CARBURETOR DISASSEMBLY/REASSEMBLY

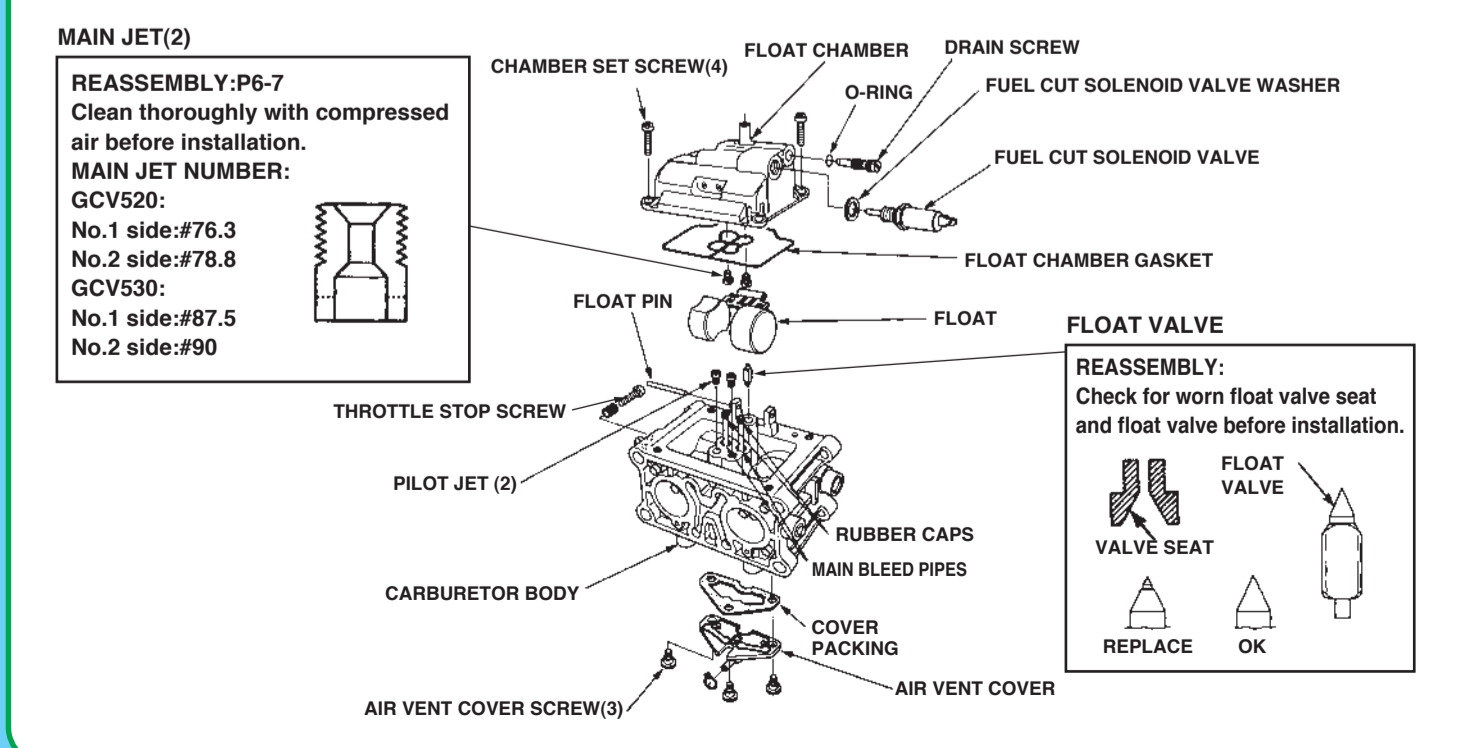

CARBURETOR REMOVAL/INSTALLATION

